

PROCESO CONSTRUCTIVO

FUNDACIÓN

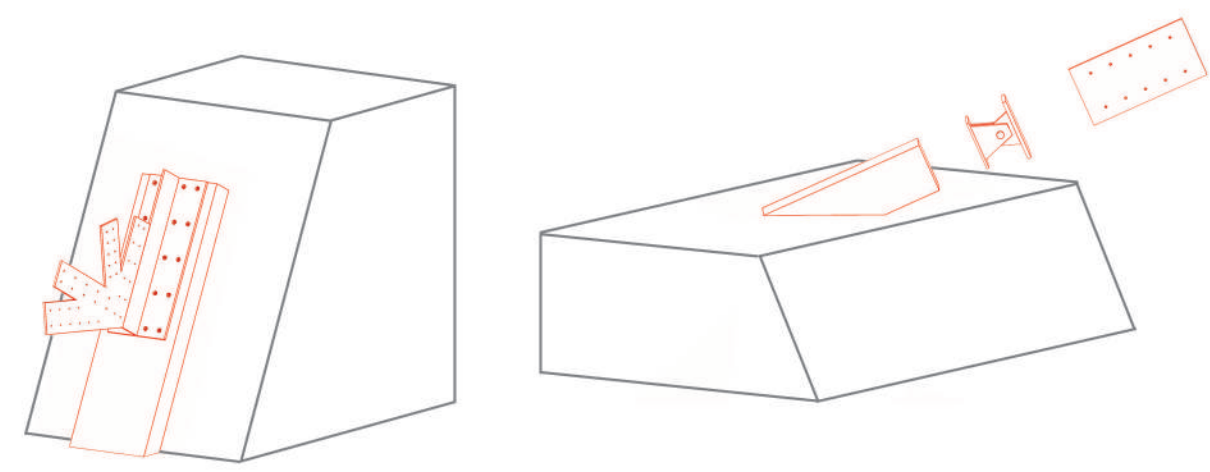

LA ESTRUCTURA CENTRAL DEL PUENTE SE DIVIDE EN TRES PARTES.

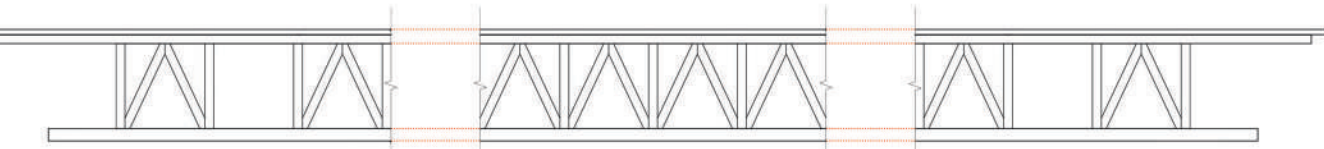

SE INSTALAN LAS VIGAS DE LA PARTE INFERIOR.

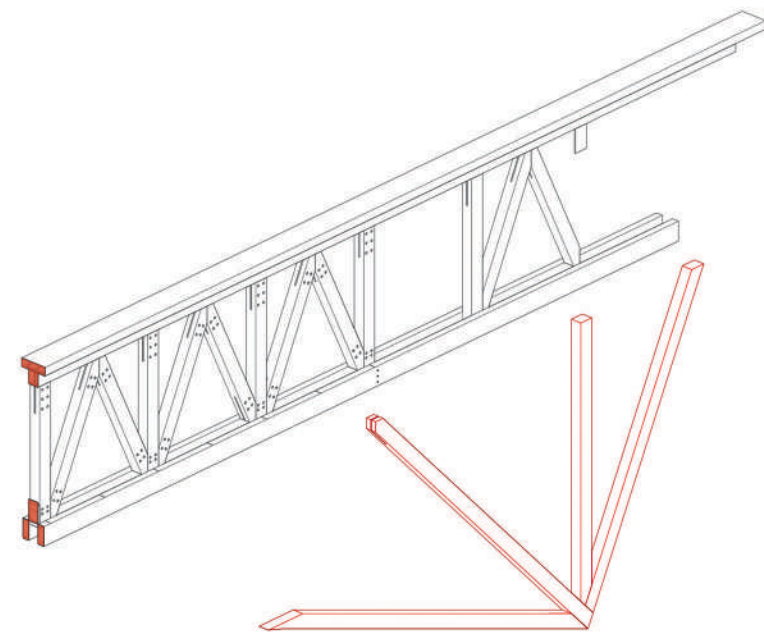

UNA VEZ UNIDA LA PARTE CENTRAL EL PUENTE SE LEVANTA CON GRUAS Y SE POSA SOBRE LA FUNDACIÓN.

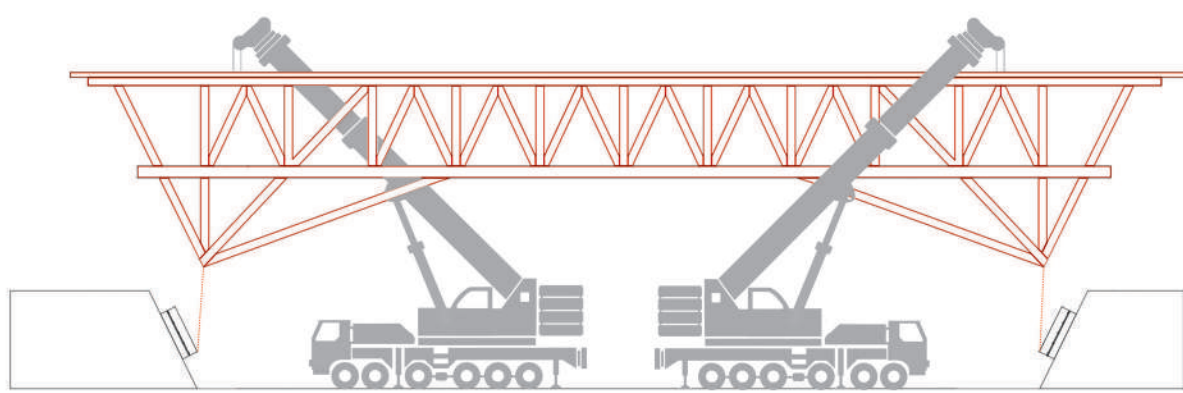

SE INSTALAN VIGAS DIAGONALES PARA MAYOR FIRMEZA DEL PUENTE Y EL PISO.

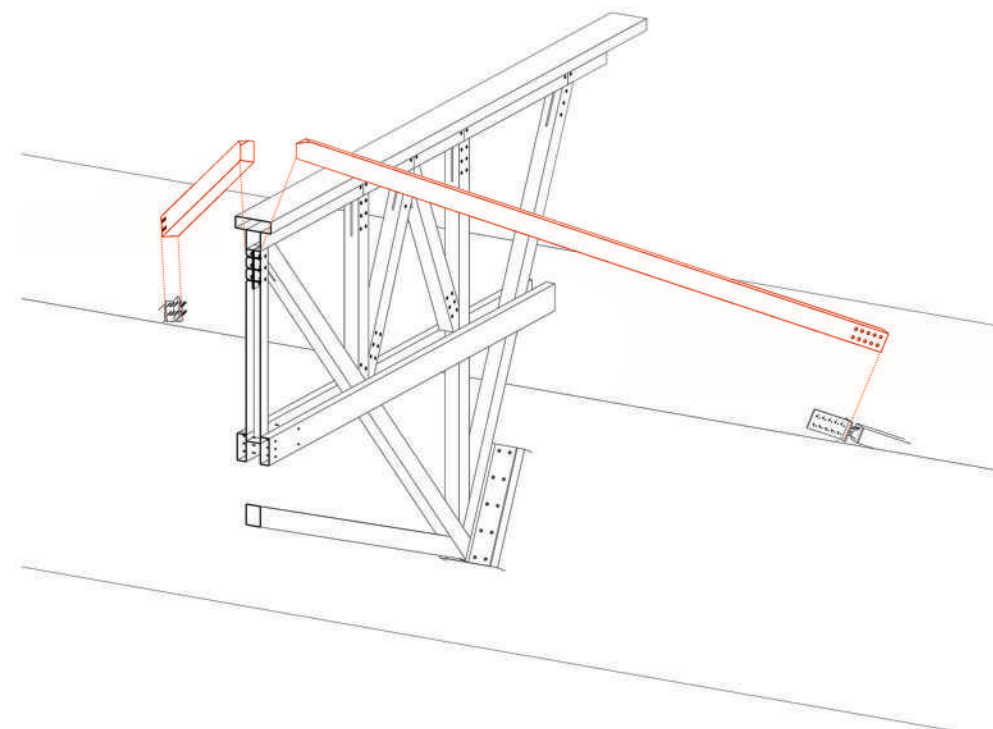

ENTRAMADO DE PISO

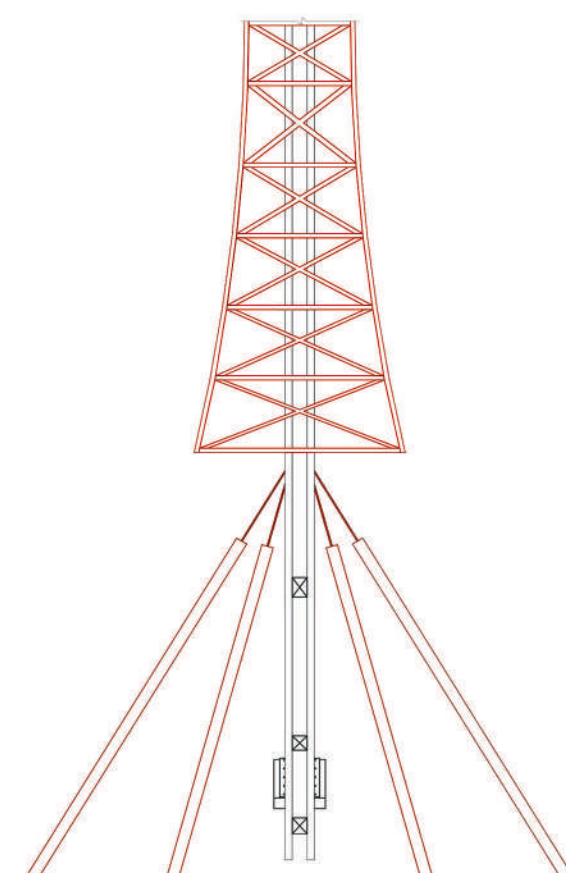

DETALLES Y PROCESO CONSTRUCTIVO

